



A Division of Thiessen Products, Inc.

INSTRUCTION SHEET FOR TOOL #1090

JIMS NEW & IMPROVED MINI VALVE SPRING TESTER 0 TO 1000 P.S.I. GAUGE

This easy to use spring tester may be used in either a bench vice, arbor, hydraulic, screw, or a drill press. This tool will fit any dual rate or conical valve spring with O.D. no larger than 1.6" diameter. Cylinder body and piston are manufactured from 6061-T6 aluminum. Steel spring plates and mandrel will provide years of service. We have topped off this tool with a precision pressure gauge covered with a protective rubber boot, reducing shock to gauge during handling and use.

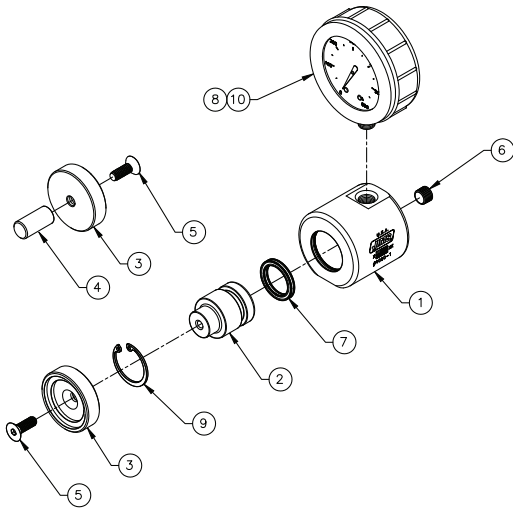

PARTS AVAILABLE SEPARATELY

No.	Qty.	Description	Part No.
1	1	PISTON BODY, SPRING TESTER	1090-1
2	1	PISTON, SPRING TESTER	1090-2
3	2	PRESSURE PLATE, SPRING TESTER	1090-3
4	1	MANDREL, SPRING TESTER	1090-4
5	2	1/4-20 X 3/4" FLAT HEAD SOCKET SCREW	1722
6	1	1/8" NPT PLUG	1201
7	1	QUAD SEAL	1089
8	1	GAUGE, PRESSURE, 0-1000, 1/4 NPT BOTTOM	1104
9	1	RETAINING RING	1131
10	1	COVER, GAUGE BOOT	1132
11	1	INSTRUCTION SHEET	1090-IS

NOTE: PLEASE READ ALL INSTRUCTIONS COMPLETELY BEFORE PERFORMING ANY WORK! IF YOU DO NOT KNOW WHAT YOU ARE DOING, DO NOT DO IT! ALWAYS WEAR SAFETY GLASSES OR OTHER FACE AND EYE PROTECTION SUCH AS FULL FACE SHIELD. JIMS® IS NOT RESPONSIBLE FOR DAMAGE, INJURY, OR THE QUALITY AND SAFETY OF YOUR WORK. Perform all work per service manual for appropriate year and model of the motorcycle you will be repairing and valve spring specifications.

See JIMS® catalog for a complete listing of all engine and transmission tools.

JIMS Tools recommended for performing this service:

No. **96600-36B**, JIMS valve spring compressor tool.

No. **988**, JIMS conical valve spring collar tool, (use with tool **96600-36B**.)

No. **1762** vice soft jaws

OTHER TOOLS RECOMMENDED FOR USE WITH THIS TOOL:

Dial calipers or scale. Both used to measure spring height.

Safety glasses

Service Manual for stock valve spring specifications or

Valve spring specifications from spring manufacturers.

SETTING UP SPRING TESTER FOR USE WITH A BENCH VICE

Note: For use in bench vise, remove mandrel from spring plate.

1. When using the tester in a horizontal position to compress spring, care should be taken to center the tester and spring to the vise jaws. This prevents any possibility of the spring taking flight. Install your vice soft jaws, open vice jaws enough so Spring Tool and the spring you will be testing can fit safely between them. **See**

Fig 1

Performance Parts For Harley-Davidson Motorcycles



A Division of Thiessen Products, Inc.

INSTRUCTION SHEET FOR TOOL #1090

- Slowly close the vice jaws down and with your dial calipers or scale set at the amount specified for the spring you're checking. View gauge, checking to see if the spring is within serviceable wear limits. See Measuring Instructions below. **See Fig 1**

Note: Let the spring set in the collapsed position for 10 seconds before recording the pressure reading.

Caution: Apply and release pressure to vice very slowly to prevent the indicator needle from bouncing.

SETTING UP SPRING TESTER FOR USE WITH A PRESS

- This will be performed the same way as in a vice, only place the spring test tool on the press table for a better view of gauge.
- Perform all the steps outlined above.

SETTING UP SPRING TESTER FOR USE WITH A DRILL PRESS

- This will be performed the same way as a vice, only place the spring test tool on the drill press table for a better view of gauge.
- Perform all the steps as outlined above.

Measuring Instructions-

1. Non Tapered Spring: If your spring rating is 515 LBS at 1.280, your spring will locate in the first step of the two plates. Measurement - .200

Example:

$1.280 - .200 = 1.080$ Actual measurement

2. Tapered Spring: If your spring rating is 480 LBS at 1.250, the large end will locate in the first step of plate 1 and the small end will locate in the second step of plate 2 measurement. - .300

Example:

$1.250 - .300 = .950$ Actual measurement

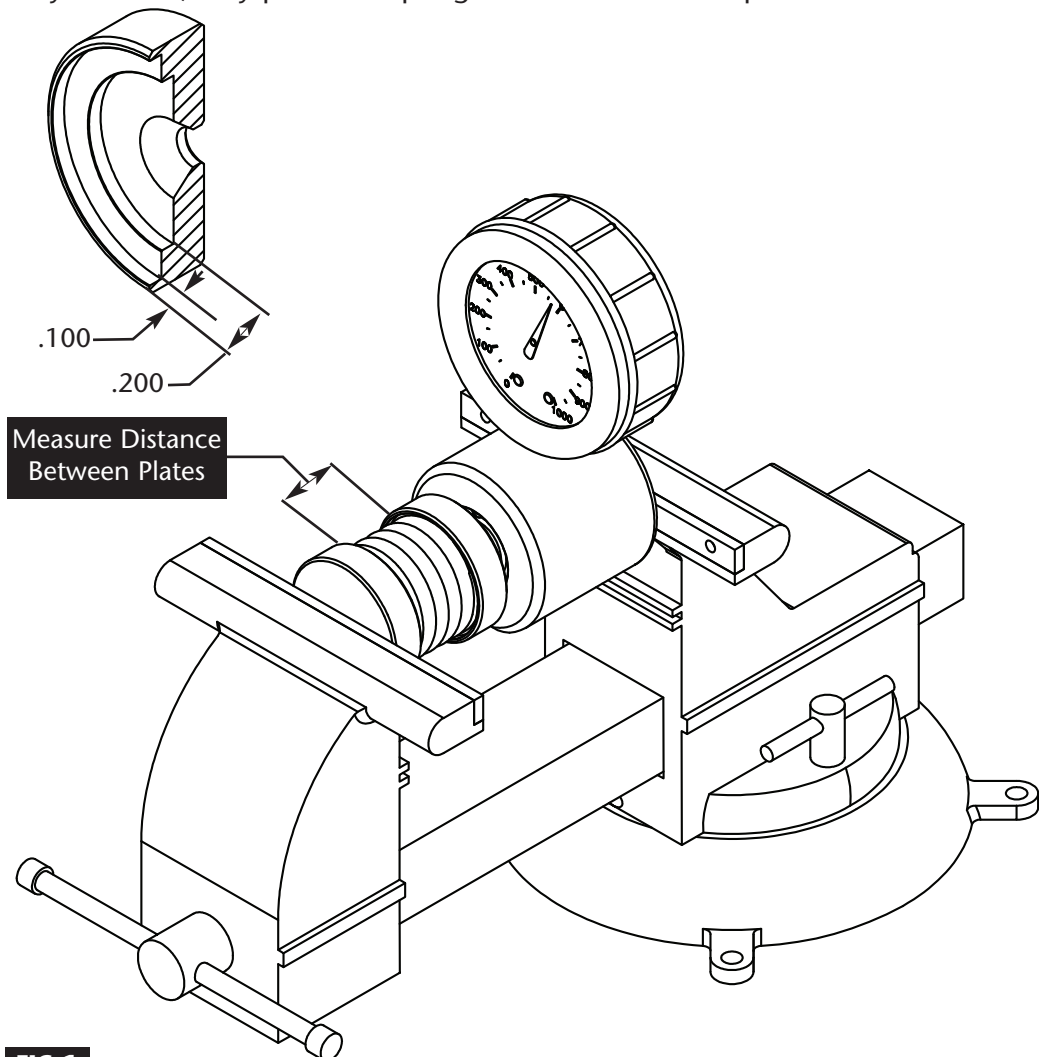

FIG 1

Performance Parts For Harley-Davidson Motorcycles