



INSTRUCTION SHEET FOR #25258-80A



POLISHED BILLET CAM COVER 1973-1992 EVOLUTION BIG TWIN MODELS

REFER TO H-D® SERVICE MANUAL
FOR SPECIFICATIONS.

NOTE: READ ENTIRE INSTRUCTION
SHEET BEFORE DOING THE JOB.

1. Start with a clean motor and a clean area to work in.
2. Remove old cam cover per H-D® Service Manual. Be sure to disconnect the battery ground wire.
3. Remove wires from the coil on 1973 to 1979 models and on 1980 to present remove sensor wire.
4. Pull wires through old cam cover.
5. Push ignition wires through hole in new outer cover and install connector then set aside for now.
6. Remove all old gasket material from motor case.
7. Next if your cam shaft end play was to specifications then measure the height of the old cam bushing from cover base to top of bushing, it should be approximately .060 +/- .001. JIMS® cam cover bushing will be the same. If your old bushing is different determine the difference and shim cam as needed, see H-D® service manual.
8. If you would like to check the centerline of your cam do so as follows: remove nut on pinion shaft with JIMS® tool #94555-55A prior to 1993. Remove pinion gear from shaft using JIMS® tool #96830-51. With cam shaft in motor, all shims off cam, and with your new JIMS® cam cover in hand, lube bushing, seal, and the two dowel pins on motor case. Set cam into inner bearing, slip cam cover over end of cam, push into the two dowel pins. Lube the 6 mounting screws provided in kit 1/4-20 x 1-1/8, torque to 90 inch/lbs. Turn cam with fingers 360 degrees from all the way to the inward position to all the way outward position. Cam should turn freely without any tight spots. If your cam does have a tight spot, or will not turn, recheck cam to bushing specifications. See H-D® Service Manual. If bushing and cam are to specs you have a possible centerline mismatch from inner cam bearing to cam cover. To fix this remove cam cover bushing, install new JIMS® bushing #25581-70 with JIMS® tool #1012-70TB and ream from your motor case with JIMS® cam line reamer tool #1023-70. It is also possible that your pinion bushing centerline may be off. If you are replacing cam bushing, do the pinion bushing also. Remove pinion bushing with JIMS® tool #95760-TP, reinstall with JIMS® tool #1013-54TB and line ream with JIMS® tool #94805-57.
9. Place gasket on motor case, followed by your new cam cover with assembly lube in both bushings and the sealing lip of seal and just a tad on the two dowel pins.

"FROM THE TRACK... TO THE STREET!"

10. Apply lube to the 6 mounting screws provided in kit. These are 1/4-20 x 1 1/8, JIMS® #2028, allen screws. Torque to 90-120 in./lbs. in a criss cross pattern. Torque in 30 in./lbs. increments.
11. Apply a small amount of assembly lube to the 2 o-rings just to hold into place on inner cover. The small o-ring goes around cam seal o-ring groove #5. The big o-ring goes in the outer o-ring groove on inner cover #6. Apply a small amount of lube to the 2 dowel pins on inner cover. Slip outer cam cover over these two dowel pins followed by the 2 screws 1/4-20 x 1 1/2 allens, JIMS® #2027, (see parts list) these 2 screws go in the top holes #3(see illustration). 2 of the 1/4-20 x 1 1/8 screws go into the bottom. Apply a small amount of gasket sealer to all 4 screws and torque to 90-120 in./lbs. in a criss cross pattern. Torque in 30 in./lbs increments.
12. Mount timer assembly and reconnect wires. Time engine per H-D® service manual.
13. Both cam bushing and pinion bushing are sized to H-D® specifications.

Note: cam seal CR#9837 or JIMS® #2169. Small o-ring material V747-75 Fluorocarbon #2-030-75Ω or JIMS® #2170. Big o-ring material V747-75 Fluorocarbon #2-161-75 or JIMS® # 2171. All available from JIMS®, JIMS® distributors or at a bearing house.

Caution: Excessive force may damage parts! Use safety glasses!

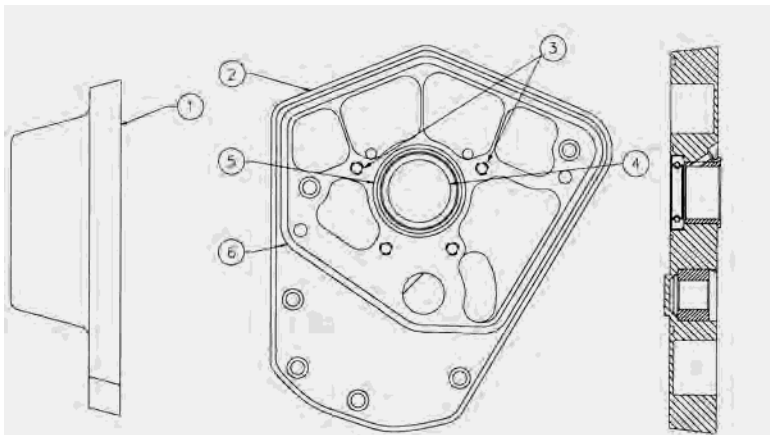

PARTS AVAILABLE SEPARATELY

No.	Qty.	Description	Part No.
1	1	CAM COVER OUTER	2412
2	1	BASE PLATE - EARLY	25258-80AP
2	1	BASE PLATE - LATE	25254-93AP
3	2	PIN LOCK - USE ON ALL MODELS, REP. H-D No. 275	2201
4	1	SEAL CAM - USE ON 1970-PRESENT, REP. H-D No. 83162-51	2169
5	1	O-RING SMALL	2170
6	1	O-RING LARGE	2171
7	2	SOCKET HEAD CAP SCREW	2027
8	8	SOCKET HEAD CAP SCREW	2028

WARRANTY

All JIMS® parts are guaranteed to the original purchaser to be free of manufacturing defects in materials and workmanship for a period of six (6) months from the date of purchase. Merchandise that fails to conform to these conditions will be repaired or replaced at JIMS® option if the parts are returned to us by the dealer (purchaser) within the six (6) month warranty period or within ten (10) days thereafter.

In the event warranty service is required, the original purchaser must call or write JIMS® immediately with the problem. Some problems can be rectified by a telephone call and need no further course of action. A part suspected of being defective must not be replaced by a dealer without prior authorization from JIMS®. If it is deemed necessary for JIMS® to make an evaluation to determine whether the part is defective, it must be packaged properly to prevent further damage and be returned prepaid to JIMS® with a copy of the original invoice of purchase and a detailed letter outlining the nature of the problem, how the part was used and the circumstances at the time of failure. If after an evaluation has been made by JIMS® and the part was found to be defective, repair, replacement or credit will be granted.

ADDITIONAL WARRANTY PROVISIONS

- 1.) JIMS® shall have no obligation in the event a JIMS® part is modified by any other person or organization.
- 2.) JIMS® shall have no obligation if a JIMS® part becomes defective in whole or in part as a result of improper installation, improper maintenance, improper use, abnormal operation, or any other misuse or mistreatment of the part.
- 3.) JIMS® shall not be liable for any consequential or incidental damages resulting from the failure of a JIMS® part, the breach of any warranties, the failure to deliver, delay in delivery, delivery in nonconforming condition, or for any other breach of contract or duty between JIMS® and a customer.
- 4.) JIMS® parts are designed exclusively for use in Harley-Davidson® Motorcycles. JIMS® shall have no warranty or liability obligation if a JIMS® part is used in any other application.

"FROM THE TRACK... TO THE STREET!"